

# Kinematics simulation and srealization of manipulator gripping items based on genetic algorithm

XIANG YAO<sup>2</sup>, AO JIANG<sup>2</sup>, CHANGQING SU<sup>3</sup>, HAOWU  
ZHAO<sup>3</sup>, MING CHENG<sup>3</sup>

**Abstract.** In the ever-changing science and technology today, the robot in the manufacturing industry is widely used. How to accurately control the robot, the efficient grasp of the target object is particularly important. In this paper, the physical model of six-degree-of-freedom manipulator under DH coordinates is established to simplify the target problem, establish the inverse kinematic equation of the manipulator, and use the genetic algorithm to apply the combined problem. Under the condition of known target coordinate, and the reciprocal motion equation is used to find the corner of each arm, and the result is verified by the positive kinematics equation. It can be seen from the simulation results that the joint angle obtained by the genetic algorithm is consistent with the kinematics equation of the Robotics toolbox. It is proved that the control of the manipulated object is effective and feasible by the genetic algorithm. High.

**Key words.** Manipulator, matlab, genetic algorithm, kinematics equation.

## 1. Introduction

At present, many applications in industry and agriculture, you can see the robot on the use of the arm, the need to operate the object to accurately detect and automatically sort the problem of crawling. Such as in agriculture, the face of the whole farm of fruit crops, how to automatically carry out individual testing, crawling and quality classification; in terms of logistics, with tens of thousands of express letters, how to carry out rapid detection and sorting; in the field of fire, how to timely identify of fire and rapid fire fighting and so on.

This paper mainly studies how to improve the accuracy of manipulator grasping

---

<sup>1</sup> Acknowledgement - Fund Project: National Natural Science Foundation of China: 5150540

<sup>2</sup> Workshop 1 - Department of Mechanical Engineering XiangTan University, XiangTan 411105, China

<sup>3</sup> Workshop 2 - Department of Information Engineering XiangTan University, XiangTan 411105, China

objects. How to make the manipulator reach the target accurately and efficiently under the condition of the known target position, and how to reduce the computational error, optimize the attitude of the robot arm and work efficiency and quality of work. Firstly, the inverse kinematics equation model based on D-H coordinate system is established, and then the genetic algorithm is used to solve the model. Finally, the results are simulated by Matlab.

## 2. Theory

### 2.1. The principle and calculation of D-H coordinate method

2.1.1. *The establishment of joint coordinate system* The D-H coordinate method has a series of parameters and methods of determination. The first is the establishment of each joint coordinate system:

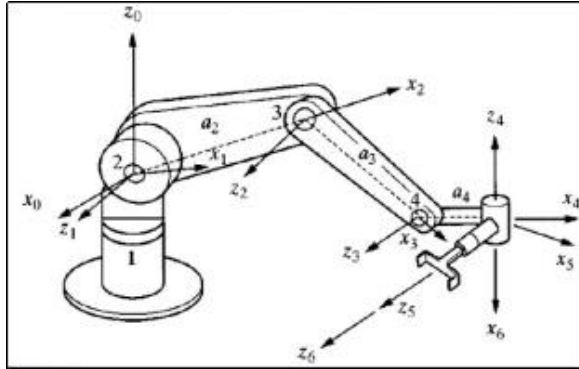

Fig. 1. The coordinates of each joint of the manipulator

1. Nomenclature of joints: the first joint from the base is named  $n$ , the next named  $n+1$ , and so on, to name the back of the joint;

2. Z axis: The mechanical arm is a rotating joint, there is no moving joint, then the direction of the Z axis can be determined by the right hand rule, as its rotation direction;

X axis: When parallelling to the adjacent Z axis, take a common vertical line which is collinear with the vertical line of the front joint; if the two Z axis intersects, the X axis is determined by the two Z axis, and the direction is their cross product direction;

Y axis: The cross product direction of X axis and Z axis;

3. Joint parameter determination: the change of coordinate system between joints is represented by specific parameters, including four parameters. The parameters are determined by the individual coordinate systems, making it easy to use mathematical methods to calculate the movement of the manipulator.

2.1.2. *Transformation of joint coordinate system* Through the above steps, a reference coordinate system is transformed into the next reference coordinate system:

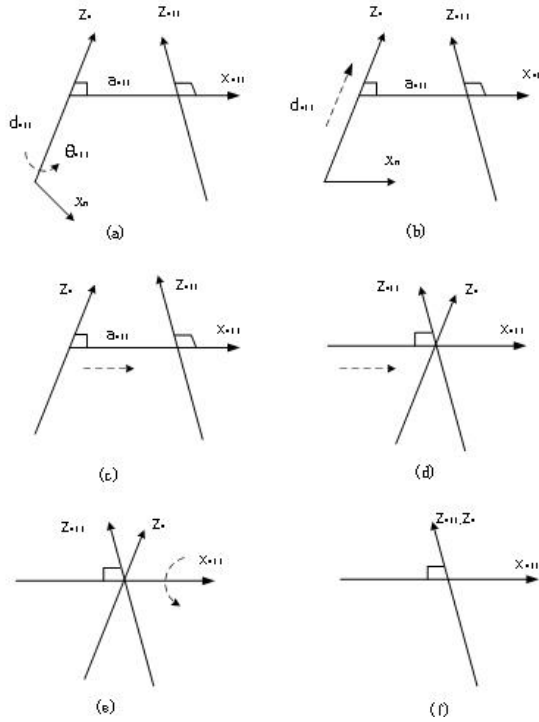

Fig. 2. Transformation of coordinate system

1. Rotate the first coordinate system around its Z axis;
2. Translate the first coordinate system along the Z axis, making the two X-axis collinear; moving distance  $d_{n+1}$ ;
3. Translate along the X axis of the first coordinate system so that its origin position is the same as the position of the second coordinate system. The moving distance is  $a_{n+1}$ ;
4. Finally, rotate the first coordinate system around its X axis so that the Z axes of the two coordinate system coincide with each other, so that the two coordinate systems coincide exactly;

2.1.3. *Kinematics equation calculation process* Determine the relevant parameters, you can use mathematical methods, the establishment of kinematic equations, the movement of the arm to solve the situation.

The joint matrix for each joint is established as follows:

$$R = 1 \tag{1}$$

The A matrix of each joint is as follows:

$$A_1 = \begin{bmatrix} C_1 & 0 & S_1 & 0 \\ S_1 & 0 & -C_1 & 0 \\ 0 & 1 & 0 & 0 \\ 0 & 0 & 0 & 1 \end{bmatrix} \quad (2)$$

$$A_2 = \begin{bmatrix} C_2 & -S_2 & 0 & C_2 a_2 \\ S_2 & C_2 & 0 & S_2 a_2 \\ 0 & 0 & 1 & 0 \\ 0 & 0 & 0 & 1 \end{bmatrix} \quad (3)$$

$$A_3 = \begin{bmatrix} C_3 & -S_3 & 0 & C_3 a_3 \\ S_3 & C_3 & 0 & S_3 a_3 \\ 0 & 0 & 1 & 0 \\ 0 & 0 & 0 & 1 \end{bmatrix} \quad (4)$$

$$A_4 = \begin{bmatrix} C_4 & 0 & -S_4 & C_4 a_4 \\ S_4 & 0 & C_4 & S_4 a_4 \\ 0 & -1 & 0 & 0 \\ 0 & 0 & 0 & 1 \end{bmatrix} \quad (5)$$

$$A_5 = \begin{bmatrix} C_5 & 0 & S_5 & 0 \\ S_5 & 0 & -C_5 & 0 \\ 0 & 1 & 0 & 0 \\ 0 & 0 & 0 & 1 \end{bmatrix} \quad (6)$$

$$A_6 = \begin{bmatrix} C_6 & -S_6 & 0 & 0 \\ S_6 & C_6 & 0 & 0 \\ 0 & 0 & 1 & 0 \\ 0 & 0 & 0 & 1 \end{bmatrix} \quad (7)$$

Establish a total transformation from the base to the end of the hand, from the base, from the first joint to the second joint, and then to the third joint, to the end of the arm

$${}^R T_H = {}^R T_1 {}^1 T_2 {}^2 T_3 \dots {}^{n-1} T_n = A_1 A_2 A_3 \dots A_n \quad (8)$$

So the total change of the Manipulator is

$${}^R T_H = A_1 A_2 A_3 A_4 A_5 A_6$$

$$= \begin{bmatrix} C_1(C_{234}C_5C_6 - S_{234}S_6) & C_1(-C_{234}C_5C_6 - S_{234}C_6) & C_1(C_{234}S_5) & C_1(C_{234}a_4 + C_{23}a_3 + C_2a_2) \\ -S_1S_5C_6 & +S_1S_5S_6 & +S_1S_5 & \\ S_1(C_{234}C_5C_6 - S_{234}S_6) & S_1(-C_{234}C_5C_6 - S_{234}C_6) & S_1(C_{234}S_5) & S_1(C_{234}a_4 + C_{23}a_3 + C_2a_2) \\ +C_1S_5S_6 & -C_1S_5S_6 & +C_1C_5 & \\ S_{234}C_5C_6 & -S_{234}C_5C_6 + C_{234}C_6 & S_{234}S_5 & S_{234}a_4 + S_{23}a_3 + S_2a_2 \\ 0 & 0 & 0 & 1 \end{bmatrix} \quad (9)$$

The inverse kinematics of the manipulator is solved as follows:  ${}^R T_H = A_1 A_2 A_3 A_4 A_5 A_6$

$${}^R T_H = \begin{bmatrix} n_x & o_x & a_x & p_x \\ n_y & o_y & a_y & p_y \\ n_z & o_z & a_z & p_z \\ 0 & 0 & 0 & 1 \end{bmatrix} \quad (10)$$

Followed by  $A_1^{-1}$  left by the above two matrices, can get

$$= \begin{bmatrix} n_x C_1 + n_y S_1 & o_x C_1 + o_y S_1 & a_x C_1 + a_y S_1 & p_x C_1 + p_y S_1 \\ n_z & o_z & a_z & p_z \\ n_x S_1 + n_y C_1 & o_x S_1 + o_y C_1 & a_x S_1 + a_y C_1 & p_x S_1 + p_y C_1 \\ 0 & 0 & 0 & 1 \end{bmatrix}$$

$$= \begin{bmatrix} C_{234}C_5C_6 - S_{234}S_6 & -C_{234}C_5C_6 - S_{234}C_6 & C_{234}S_5 & C_{234}a_4 + C_{23}a_3 + C_2a_2 \\ S_1(C_{234}C_5C_6 - S_{234}S_6) & S_1(-C_{234}C_5C_6 - S_{234}C_6) & S_1(C_{234}S_5) & S_{234}a_4 + S_{23}a_3 + S_2a_2 \\ -S_5C_6 & S_5S_6 & C_5 & 0 \\ 0 & 0 & 0 & 1 \end{bmatrix} \quad (11)$$

According to the third row of the fourth column of the corresponding elements can be obtained:

$$\theta_1 = \arctan\left(\frac{p_y}{p_x}\right) \quad (12)$$

According to 1,4 elements and 2,4 elements available

$$p_x C_1 + p_y S_1 = C_{234}a_4 + C_{23}a_3 + C_2a_2 \quad (13)$$

$$p_z = S_{234}a_4 + S_{23}a_3 + S_2a_2 \quad (14)$$

Add the squares of the two equations above and add and use the difference product formula

$$S_2 S_{23} + C_2 C_{34} = \cos \theta_3 \quad (15)$$

So:

$$C_3 = \frac{(p_x C_1 + p_y S_1 - C_{234}a_4)^2 + (p_z - S_{234}a_4)^2 - a_2^2 - a_3^2}{2a_2 a_3} \quad (16)$$

According to the known,  $S_3 = \sqrt{1 - C_3^2}$

And so on, followed by the equation at both ends of the left by A1 to A4 of the inverse, get

$$\begin{aligned}
 & \begin{bmatrix} C_{234}(C_1n_x + S_1n_y) + S_{234}n_z & C_{234}(C_1o_x + S_1o_y) + S_{234}o_z & C_{234}(C_1a_x + S_1a_y) + S_{234}a_x & C_{234}(C_1p_x + S_1p_y) + S_{234}p_z \\ C_1n_y - S_1n_x & C_1o_y - S_1o_x & C_1a_y - S_1a_x & -C_{34}a_2 + C_4a_3 - a_4 \\ -S_{234}(C_1n_x + S_1n_y) + C_{234}n_z & -S_{234}(C_1o_x + S_1o_y) + C_{234}o_z & -S_{234}(C_1a_x + S_1a_y) + C_{234}a_x & 0 \\ 0 & 0 & 0 & -S_{234}(C_1p_x + S_1p_y) + C_{234}p_z \\ & & & +S_{34}a_2 + S_4a_3 \\ & & & 1 \end{bmatrix} \\
 & = \begin{bmatrix} C_5C_6 & -C_5S_6 & S_5 & 0 \\ S_5C_6 & -S_5S_6 & -C_5 & 0 \\ S_6 & C_6 & 0 & 0 \\ 0 & 0 & 0 & 1 \end{bmatrix} \quad (17)
 \end{aligned}$$

After the robot arm is modeled by the D-H coordinate method, Determine the joint parameters, use the parameters to calculate the transfer matrix, and through the inverse kinematics equation to calculate the robot arm to grab the target object when the joint angle value combination. Based on this calculation, we can verify the accuracy of the corner combination proposed by the genetic algorithm.

## 2.2. Principle and Characteristics of Genetic Algorithm

## 3. Robot Modeling and Algorithm Implementation

In the D-H coordinate system, the mechanical arm model can simplify the problem and simulate under the Matlab environment. The manipulator can be rotated by using the Robotics toolbox. The concrete steps are as follows:

As shown in Figure 3.1, we place the manipulator in the following coordinate system. The target object is considered as a particle P (x0, Y0, Z0), the robot arm base is always around the Z axis, from the direction of positive x axis rotation, three-dimensional space can be used to study the joint rotation of the robot arm, And the arm of the arm can be measured, here according to the actual situation of the corresponding input length.

### 3.1. The Flowchart of Genetic Algorithm in Trajectory Planning

Genetic algorithm has the advantages of high adaptability to manipulator trajectory planning, parallel computing and searching for optimal solution, and its operation process is as follows:

*3.1.1. Chromosome coding* The coding method of the legacy algorithm determines the efficiency of the algorithm. Often use a fixed length of the binary symbol, can be expressed in the group of individuals, the chromosome allele, respectively,

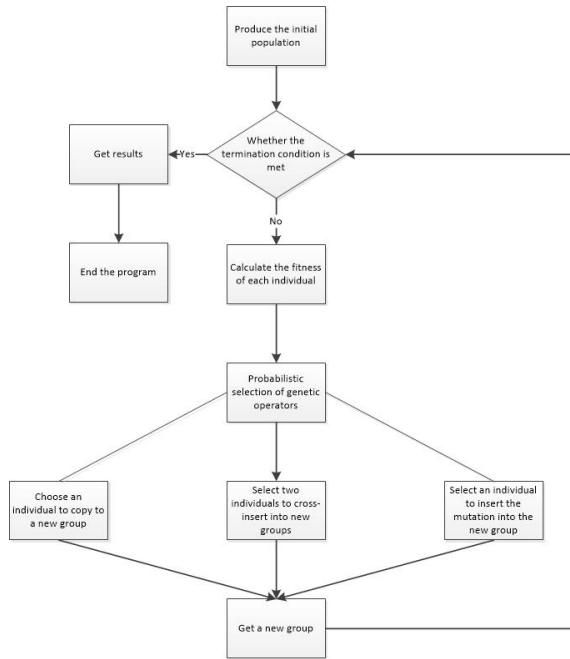

Fig. 3. Genetic algorithm principle

by 0 and 1, a number of points are expressed as 0 and 1 composed of digital string. Individual chromosomes in the initial population can be expressed as random values, but they require uniform distribution of genes within the population.

*3.1.2. Initial population setting* The initial population can be created by the method of generating random numbers, the initial population size should be appropriate, too small will affect the diversity of the population, too much will lead to too slow operation speed.

The following figure shows the initial population setting of the joint 1:

Other joints also set the initial population in turn.

Individual fitness assesses the fitness of individuals within a population and determines the probability that they can inherit genetic information into the next generation in this generation. The higher the fitness, the greater the probability that the gene will be transmitted. To determine the probability of each individual in the current population to be inherited to the next generation.

Each of the steering gear rotation range parameters, we thus establish the following coordinate error squared sum minimum path model:

$$\min W = |z_0 - l_1 - l_2 \times \cos(\theta_2) - l_3 \times \cos(\theta_2 + \theta_3) - l_4 \times \cos(\theta_2 + \theta_3 + \theta_4)|^2,$$

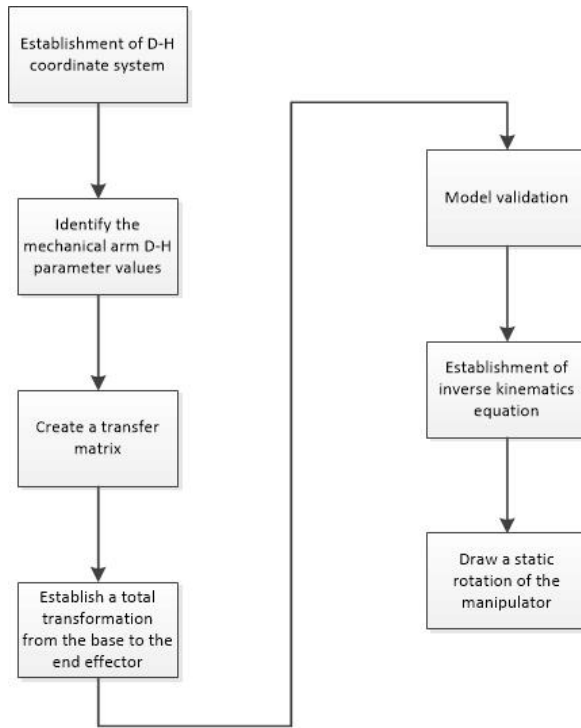

Fig. 4. D-H coordinate method operation step

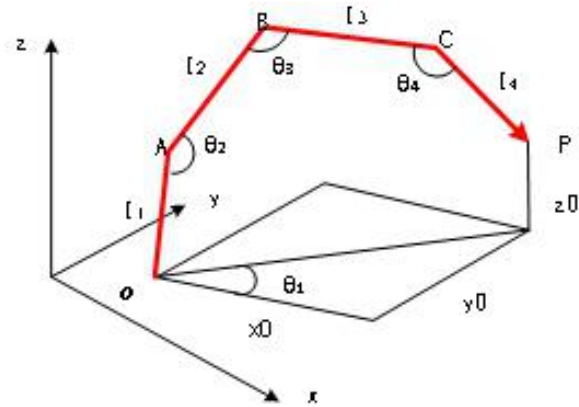

Fig. 5. Modeling of Manipulator under D-H Coordinate

$$\begin{cases} -\pi < \theta_2 < \pi \\ -\pi < \theta_3 < \pi \\ -\pi < \theta_4 < \pi \end{cases} \quad (18)$$



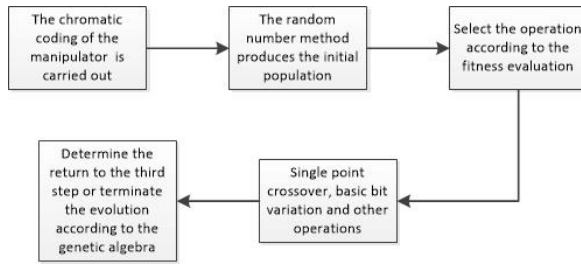

Fig. 6. The Process of Genetic Algorithm in Trajectory Planning

	A	B	C	D	E	F	G	H	I	J
	VarName1	VarName2	VarName3	VarName4	VarName5	VarName6	VarName7	VarName8	VarName9	VarName10
1	76.7175	73.4107	70.5362	68.0617	65.9389	64.1169	62.5479	61.1903	60.0092	58.9753
2	74.7104	71.1529	68.1661	65.6739	63.5924	61.8450	60.3677	59.1087	58.0267	57.0896
3	72.0812	68.3183	65.3006	62.8769	60.9137	59.3052	57.9711	56.8513	55.9007	55.0853
4	68.5605	64.7362	61.8450	59.6244	57.8847	56.4944	55.3628	54.4266	53.6407	52.9727
5	63.7843	60.2328	57.7317	55.9007	54.5128	53.4292	52.5620	51.8535	51.2644	50.7673
6	57.3876	54.7200	52.9727	51.7479	50.8447	50.1524	49.6055	49.1628	48.7973	48.4905
7	49.3731	48.3549	47.7202	47.2870	46.9726	46.7341	46.5470	46.3964	46.2724	46.1687
8	40.6269	41.6451	42.2798	42.7130	43.0274	43.2659	43.4530	43.6036	43.7276	43.8313
9	32.6124	35.2800	37.0273	38.2521	39.1553	39.8476	40.3945	40.8372	41.2027	41.5095
10	26.2157	29.7672	32.2683	34.0993	35.4872	36.5708	37.4380	38.1465	38.7356	39.2327
11	21.4395	25.2638	28.1550	30.3756	32.1153	33.5056	34.6372	35.5734	36.3593	37.0273
12	17.9188	21.6817	24.6994	27.1231	29.0863	30.6948	32.0289	33.1487	34.0993	34.9147
13	15.2896	18.8471	21.8339	24.3261	26.4076	28.1550	29.6323	30.8913	31.9733	32.9104
14	13.2825	16.5893	19.4638	21.9383	24.0611	25.8831	27.4521	28.8097	29.9908	31.0245

Fig. 7. Joint 1 initial population setting

As long as the  $w$  reaches the minimum, the actual arrival of the robot arm to the coordinates of the coordinates and the minimum target error, the corresponding set of corner values that meet our requirements.  $x_0, y_0, z_0$  can be input by computer simulation. The smaller the value of  $W$  is, the difference between the actual arrival position and the target coordinate of the end of the manipulator is the smallest, and the corresponding corner value satisfies the best result.

## 4. Result

### 4.1. Variation of fitness

Using Matlab software, input instructions in the program, draw the genetic algorithm evolution process of each generation fitness average and the best value Output graphics as:

As can be seen from the diagram, in the early days of evolution, the mean of the population fitness is very different from the optimum. After several generations of evolution, the curve converges quickly and is close to the optimum.

In the 50th generation to the 100th generation, the fitness mean curve shows some fluctuation, which is reflected in the evolutionary process of variation, can expand the search range, to prevent into the local optimal solution.

After the evolution of 200 generations, the fitness average is almost coincident with the optimal value, we can see that through the genetic algorithm, the required angle combination tends to the optimal solution.

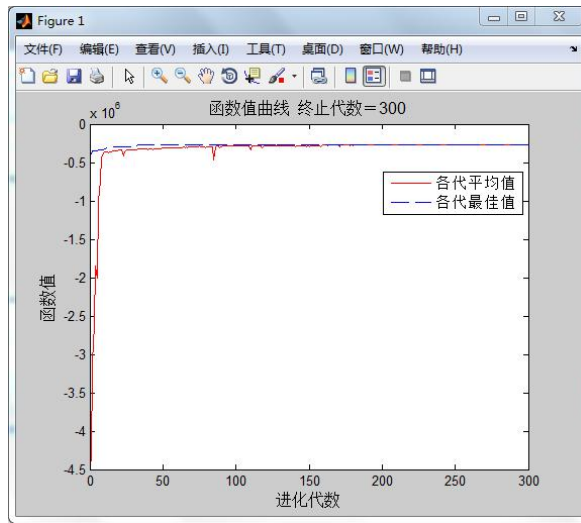

Fig. 8. Adaptive change chart

**4.2. Calculation of arm angle calculation**

Through the Matlab software Robotics toolbox to draw the manipulator rotation static map, followed by input arm data.

In the D-H coordinate, the parameters of the manipulator are set out as shown in the table:

j	theta	d	a	alpha	offset
1	q1	10.1	0	1.571	0
2	q2	0	12.3	0	0
3	q3	0	13.8	0	0
4	q4	0	0	-1.571	0
5	q5	15.5	0	0	0

Fig. 9. Parameter setting in D-H coordinates

The following figure shows the results of the calculated results of the Matlab command line window.

**4.3. Motion trajectory simulation results**

When the set target coordinates are (20, 25, and 30), the resulting robot arm diagram is as follows:

Simulation results get a three-dimensional static map, you can switch the viewing angle to view the attitude of the arm. The graph (a) is an observation of the overall view of the robot arm. D (b), (c) and (d) are the main view, left and top view of the robot arm, respectively. From the simulation results of the static rotation

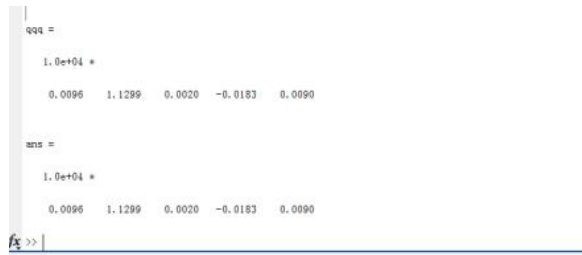

Fig. 10. Comparison of calculation results

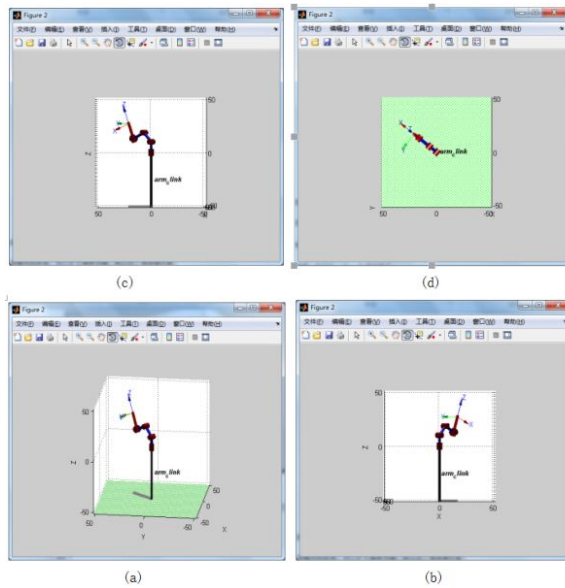

Fig. 11. Manipulator simulation

diagram of the manipulator, it can be seen that the position of the mechanical claw is in accordance with the position of the target particle under the three-dimensional coordinate, and the corner error of the genetic algorithm is smaller.

By changing the target coordinates to verify, the results are as follows:

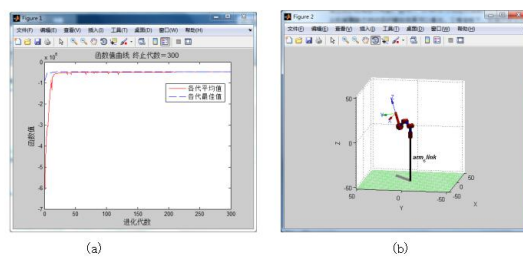

Fig. 12. Change the simulation results of the target

When the above figure is the target coordinate (30,25,20), the fitness curve and the robot simulation chart show that the simulation result is in accordance with the expectation and the error is small.

The setting parameters of genetic algorithm have a great impact on the search, the comparison of this simulation through multiple sets of parameters, the population was 95, the crossover probability is 0.6, the mutation probability is 0.01, set the parameters for the 300 generation of the termination of the evolution algebra, simulation can achieve good results.

Xy0\_test

29.71 375	30.41 287	31.08 361	31.97 296	32.82 185	33.36 634	34.07 237	35.10 811	35.76 479	36.64 157
30.3 521	31.35 539	31.81 126	32.66 192	33.18 729	34.15 827	34.92 457	35.29 604	36.69 634	36.85 558
31.11 057	31.82 054	32.75 65	34.24 415	33.94 366	34.8 084	35.43 941	35.59 698	37.1 893	37.21 203
31.90 215	32.58 812	33.27 246	33.84 552	34.24 634	35.3 812	36.08 593	36.88 766	38.00 414	38.7 1954
32.6 44	33.52 829	33.81 753	34.73 627	35.38 633	35.51 881	37.37 373	37.62 895	38.24 074	38.8 152
33.44 326	34.02 551	34.7 6305	35.46 351	35.90 851	36.5 3993	36.98 482	38.46 813	38.82 578	38.46 618
34.13 346	34.88 244	35.42 255	35.93 73	37.79 039	37.35 16	38.30 509	39.43 888	39.90 223	39.66 375
34.67 082	34.89 866	36.06 322	36.7 071	37.80 394	38.19 418	39.0 7962	39.39 86	40.33 802	41.18 374
36.14 311	36.42 183	36.87 918	38.20 848	38.14 976	38.79 147	39.52 814	40.27 645	40.36 994	40.37 768
37.05 58	37.64 535	37.48 188	38.97 218	38.08 982	39. 348	40.3 609	40.50 283	41.33 017	41.0 053

Z0\_tst

9.989 459	10.00 028	10.00 042	9.987 039	10.03 243	10.03 161	10.07 184	9.940 541	10.00 37	9.990 342
10.01 697	9.965 979	10.00 769	9.986 666	9.986 311	9.97 044	9.992 359	10.03 197	9.975 794	10.08 824
10.01 237	10.00 047	9.938 492	9.862 004	10.00 269	9.964 469	10.00 268	10.14 091	9.946 531	10.14 459
9.99 599	10.00 459	9.985 849	10.01 08	10.06 632	10.00 009	10.00 206	9.99 5911	10.1 012	9.92 554
10.00 016	9.930 028	10.00 566	9.964 048	10.00 996	9.953 627	9.928 469	10.01 418	10.00 052	10.03 433
10.00 236	10.02 065	10.00 998	9.956 994	10.05 764	10.00 685	9.993 667	9.948 346	10.01 315	10.47 487
10.03 597	9.99 9242	10.00 134	9.990 44	10.03 525	10.00 362	10.01 191	9.862 855	9.935 677	9.933 895
10.03 191	10.03 423	10.03 006	10.04 515	9.933 279	10.00 181	9.939 312	10.02 232	9.99 419	9.98 5092
9.98 5205	9.99 5286	10.04 991	9.81 3105	9.970 328	10.01 237	10.0 0028	9.99 9205	9.95 5175	10.1 8858
9.88 5051	9.87 2585	10.0 199	9.93 5527	10.32 626	10.09 774	10	9.99 5216	10.00 998	10.13 627

 $\Delta xy0$

0.015 262	-0.00 095	-0.06 121	0.08 2521	0.17 219	-0.05 521	-0.13 289	0.10 811	-0.04 023	0.02 1907
-0.06 172	0.24 2692	-0.01 64	0.104 278	-0.11 436	0.09 9497	0.096 424	-0.31 295	0.29 5791	-0.34 657
-0.03 425	-0.00 712	0.229 587	1.00 2608	-0.02 691	0.09 5291	-0.02 888	-0.63 836	0.175 793	-0.59 008
0.011 708	0.03 0481	0.03 0916	-0.0 956	-0.40 911	-0.00 242	-0.03 885	0.00 9477	0.361 075	0.300 791
-0.00 566	0.22 6634	-0.15 305	0.08 0825	0.03 0991	-0.55 057	0.57 6988	0.092 301	-0.04 764	-0.23 605
0.021 708	-0.03 326	0.049 936	0.079 902	-0.16 087	-0.22 963	-0.49 851	0.258 187	-0.12 29	-1.23 269
-0.07 18	0.054 292	-0.04 575	-0.18 748	0.99 3651	-0.13 173	0.121 326	0.541 579	0.2790 03	-0.69 712
-0.32 918	-0.71 033	-0.17 212	-0.17 107	0.267 293	-0.01 576	0.18 2315	-0.19 938	0.02 6732	0.147 171
0.338 081	0.021 285	-0.13 434	0.56 5415	-0.13 862	-0.15 722	-0.09 509	-0.03 484	-0.64 225	-1.34 761
0.436 129	0.44 3199	-0.32 023	0.55 3432	-0.96 143	-0.35 087	3.11 E-05	-0.53 374	-0.39 512	-1.42 111

 $\Delta Z$

-0.01 054	0.00 0281	0.00 0423	-0.01 296	0.03 2427	0.03 1606	0.071 842	-0.05 946	0.003 699	-0.00 966
0.016 973	-0.03 402	0.00 769	-0.01 333	-0.01 369	-0.02 956	-0.00 764	0.03 197	-0.02 421	0.08 8241
0.012 369	0.00 0473	-0.06 151	-0.13 8	0.00 2685	-0.03 553	0.002 685	0.140 907	- 0.053 47	0.144 585
-0.00 401	0.00 4591	-0.01 415	0.010 796	0.066 322	9.39 E-05	0.00 2058	-0.00 409	0.101 195	-0.07 446
0.000 161	-0.06 997	0.00 5662	-0.03 595	0.00 9957	-0.04 637	-0.07 153	0.014 181	0.000 522	0.034 333
0.002 359	0.020 655	0.009 981	-0.04 301	0.057 644	0.006 853	-0.00 633	-0.05 165	0.013 151	0.474 872
0.035 971	-0.00 076	0.001 337	-0.00 956	0.03 5245	0.003 617	0.01 1906	-0.13 715	-0.06 432	-0.06 611
0.031 911	0.03 423	0.03 0059	0.04 5147	-0.06 672	0.00 1809	-0.06 069	0.022 316	-0.00 581	-0.01 491
-0.01 48	-0.00 471	0.049 908	-0.18 689	-0.02 967	0.012 373	0.00 0278	-0.00 08	-0.04 482	0.18 8581
-0.11 495	-0.12 742	0.01 9903	-0.06 447	0.32 6263	0.097 739	1.63 E-06	-0.00 478	0.009 984	0.136 268

P\_xy0

0.000 514	-3.1 E-05	-0.00 197	0.00 2588	0.00 5274	-0.00 165	-0.00 389	0.00 3089	-0.00 112	0.00 0598
-0.00 203	0.0 078	-0.00 052	0.00 3203	-0.00 343	0.00 2921	0.00 2769	-0.00 879	0.00 8126	-0.00 932
-0.00 11	-0.00 022	0.00 7058	0.03 0161	-0.00 079	0.00 2745	-0.00 081	-0.01 762	0.00 4749	-0.01 561
0.000 367	0.000 936	0.000 93	-0.00 282	-0.01 181	-6.8 E-05	-0.00 108	0.000 257	0.009 592	0.007 829
-0.00 017	0.00 6805	-0.00 451	0.00 2332	0.00 0877	-0.01 526	0.01 568	0.00 2459	-0.00 124	-0.00 604
0.000 65	-0.00 098	0.00 1439	0.00 2258	-0.00 446	-0.00 625	-0.01 33	0.006 757	- 0.003 16	- 0.03105
-0.00 21	0.00 1559	-0.00 129	-0.00 519	0.027 004	-0.00 351	0.00 3177	0.01 3923	0.007 041	- 0.01727
-0.00 941	-0.01 995	-0.00 475	-0.00 464	0.007 121	-0.00 041	0.00 4687	-0.00 504	0.000 663	0.00 3586
0.009 442	0.00 0585	-0.00 363	0.01 502	-0.00 362	-0.00 404	-0.00 24	-0.00 086	-0.01 566	-0.0 323
0.01 191	0.01 1913	-0.00 847	0.014 405	-0.02 462	-0.00 884	7.7 E- 07	-0.01 301	-0.00 947	-0.03 35

P\_z0



-0.00 105	2.81 E-05	4.23 E-05	-0.00 13	0.00 3243	0.00 3161	0.00 7184	-0.00 595	0.000 37	-0.00 097
0.001 697	-0.00 34	0.00 0769	-0.00 133	-0.00 137	-0.00 296	-0.00 076	0.00 3197	-0.00 242	0.00 8824
0.001 237	4.73 E-05	-0.00 615	-0.01 38	0.00 0269	-0.00 355	0.00 0268	0.014 091	-0.00 535	0.014 459
-0.00 04	0.000 459	-0.00 142	0.00 108	0.006 632	9.39 E-06	0.000 206	-0.00 041	0.01 012	-0.00 745
1.61 E-05	-0.00 7	0.00 0566	-0.00 36	0.00 0996	-0.00 464	-0.00 715	0.00 1418	5.22 E-05	0.00 3433
0.000 236	0.002 065	0.000 998	-0.00 43	0.005 764	0.000 685	-0.00 063	-0.00 517	0.001 315	0.04 7487
0.003 597	-7.6 E-05	0.00 0134	-0.00 096	0.003 525	0.000 362	0.00 1191	-0.0 1371	-0.00 643	-0.00 661
0.003 191	0.003 423	0.00 3006	0.00 4515	-0.00 667	0.000 181	-0.00 607	0.00 2232	-0.00 058	-0.00 149
-0.00 148	-0.00 047	0.00 4991	-0.01 869	-0.00 297	0.001 237	2.78 E-05	-8 E- 05	-0.00 448	0.018 858
-0.01 149	-0.01 274	0.00 199	-0.00 645	0.03 2626	0.00 9774	1.63 E-07	-0.00 048	0.000 998	0.013 627

## 5. Discuss

There are still many deficiencies in this design. First of all, the control accuracy of the manipulator needs to be further improved. Since the understanding of the genetic algorithm does not reach a certain depth, the application method and the parameter setting are not proficient, resulting in the grasping accuracy and not to a very high level. Second, the innovation is not enough, genetic algorithm in the use of robotics has been a lot of examples. Modeling with D-H coordinates is also a standard modeling method for robotics. There are shortcomings in the way to solve the problem.

## 6. Conclusion

1). The simulation research for the mechanical arm Angle of combination of genetic algorithm for the optimal solution, by giving more groups of data of different target coordinates, ultimately, the simulation can calculate Angle combination, meet the requirements and the error is small, fast calcul. This topic from the control of six degrees of freedom manipulator, for the purpose, in order to improve the manipulator grabbing precision analysis was studied under the simulation environment of Matlab software, the simulation of the manipulator grasping objects specified location operation, through the d-h coordinate representation space model is established, in combination with genetic algorithm for the optimal Angle oation, high feasibility;

2). Using d-h coordinate representation, the establishment of a reasonable space model, can simplify the model complexity, and can through the kinematics principle, combining with the software of Robotics kit to verify the correctness of the combination of genetic algorithm for corner;

3). Powerful Matlab software drawing, not only can plot of genetic algorithm in the process of evolution fitness change, also can simulate the mechanical arm grab static figure, can be observed through changing views on the multiple perspectives, the implementation of the feasibility of genetic algorithm and simulation.

## References

- [1] JS. KIM, H.J. YONG, JH. PARK: *A geometric approach for forward kinematics analysis of a 3-SPS/S redundant motion manipulator with an extra sensor using conformal geometric algebra*. *Meccanica* 51 (2016), No. 10, 2289–2304.
- [2] S. OH, K. KONG: *Two-Degree-of-Freedom Control of a Two-Link Manipulator in the Rotating Coordinate System*. *IEEE Transactions on Industrial Electronics* 62 (2015), No. 9, 5598–5607.
- [3] DONG. QIWEI: *Optimization Design for Clamping Device of Picking Robot Manipulator Based on the Co-simulation of ADAMS and Pro/E*. *Journal of Agricultural Mechanization Research* (2017), No. 5, 226–230.
- [4] CUI. GUO. HUA, YUAN. HUI. ZHANG: *Series Manipulator Workspace Solution*. *Machinery Design & Manufacture* (2013), No. 10, 183–186.
- [5] P. XU, D. ZHAO, M. YING, J. CHENG, K. LI: *Self-motion manifold analysis on 8-DOF fiber placement manipulator*. *Journal of Southeast University* (Natural Science Edition) (2017), No. 2, 254–258.
- [6] N. HARNKARNSUJARIT, K. KAWAI, T. SUZUKI: *Impacts of freezing and molecular size on structure, mechanical properties and recrystallization of freeze-thawed polysaccharide gels*. *LWT - Food Science and Technology* 68 (2016) 190–201.
- [7] ZHU. QIL, WU. YAN: *Mechanical and Hydraulic Coupling Simulation of Control System of 4-DOF Manipulator Based on SimMechanics*. *Machine Tool & Hydraulics* (2015), No. 3, 16–19.
- [8] LX. ZHAO, SX. WANG: *LPF-based sliding mode control for robot*. *Computer Engineering and Applications*. *Computer Engineering and Applications* (2009), No. 18, 236–238.
- [9] A.J. HÄUSLER, A. SACCON, AP. AGUIAR, J. HAUSER, A. PASCOAL: *AM Pascoal. Energy-Optimal Motion Planning for Multiple Robotic Vehicles with Collision Avoidance*. *IEEE Transactions on Control Systems Technology* 24 (2016), No. 3, 867–883.
- [10] YAO. QI. JIAL, GE. XIN. SHENG: *Attitude Motion Planning of Flexible Space Robot Based on a Hybrid Optimization Strategy*. (2017), No. 3, 1–5.
- [11] Y. ZHANG, X. LV, Z. LI, Z. YANG: *Repetitive Motion Planning of Redundant Robots Based on LVI-Based Primal-Dual Neural Network and PUMA560 Example*. *Springer Berlin Heidelberg* 4689 (2007), 539–545.
- [12] MAO, ZIQIANG, HSIA, C. T.: *Obstacle avoidance inverse kinematics solution of redundant robots by neural networks*. *IEEE International Conference on Robotics & Automation* 15 (2000), No. 1, 1014.
- [13] ZHANG. Y, WANG. J, XIA. Y: *A dual neural network for redundancy resolution of kinematically redundant manipulators subject to joint limits and joint velocity limits*. *IEEE Transactions on Neural Networks* 14 (2003), No. 3, 658–67.
- [14] ZHANG. Y. N, PENG. H. ZHANG: *neural network for lineartime-varying equation solving and its robotic applicatio*. *Proceedings of the 6th International Conference on Machine Learning and Cybernetics* 6 (2007), 3543–3548.
- [15] ZHANG. Y, GE. S. S, LEE. T. H: *A unified quadratic-programming-based dynamical system approach to joint torque optimization of physically constrained redundant ma-*

- nipulators*. IEEE Transactions on Systems, Man, and Cybernetics, Part B 34 (2014), No. 5, 2126–32.
- [16] MICHALEWICZ, Z, JANCKOW, C. Z, KRAWCZYK, J. B: *A modified genetic algorithm for optional control problems*. Math. Appl 23 (1992), No. 12, 83–94.
- [17] ZHANG . Y. N, GE, S. S: *Design and Analysis of a General Recurrent Neural Network Model for Timevarying Matrix Inversion*. IEEE Transactions on Neural Networks 16 (2005), No. 6, 1477–1490.
- [18] HUANG, S. J, HUANG, K. S, CHIOU, K. C: *Development and application of a novel radial basis function sliding mode controller*. Mechatronics. 13 (2003), No. 4, 313–329.
- [19] Y. ZHANG, SS. GE, TH. LEE: *A unified quadratic programming based dynamical system approach to joint torque optimization of physically constrained redundant manipulators*. IEEE Transactions on Systems Man and Cybernetics 34 (2004), No. 5, 2126.
- [20] SS. YANG, CL. HO, CM. LEE: *HBP: improvement in BP algorithm for an adaptive MLP decision feedback equalizer*. IEEE Transactions on Circuits and Systems 53 (2006), No. 3, 240–244.
- [21] ZHANG, YUNONG, LI. WEI, YI. CHENFU, CHEN. KE: *A weights-directly-determined simple neural network for nonlinear system identification*. IEEE World Congress on Computational Intelligence (2008), 455–460.
- [22] J. DOYLE, K. GLOVER, P. KHARGONEKAR, B. FRANCIS, J. DOYLE, K. GLOVER, P. KHARGONEKAR, B. FRANCIS: *American Control Conference* 34 (2009), No. 8, 1691–1696.
- [23] ZHIGIANG. GAO: *Scaling and Bandwidth-Parameterization based Controller Tuning*. American Journal of Infection Control (2003).
- [24] MÜLLER. P. C: *Estimation and Compensation of Nonlinearities in Descriptor Systems*. 6th IFAC Symposium on Nonlinear Control Systems (2004).
- [25] S. HUANG, J. XIANG, W. WEI, MZQ. CHEN: *On the Virtual Joints for Kinematic Control of Redundant Manipulators with Multiple Constraints..*

Received November 16, 2017

